

S, SX & SXF Series

Packaged Microstepping Systems

The S Family of drives and drive/indexer systems are standalone, packaged microstepping systems. Designed for reliability, the S Series step and direction input drive, the SX Series drive/indexer, and the SXF drive/indexer with encoder following, all offer top quality performance.

Both the SX and SXF utilize Compumotor's latest X-language enhancements and are easily programmed over an RS-232C interface. These products can perform registration moves, and they are also equipped to provide complex move profiling.

Common Features

Performance

- Torques from 65 to 1,900 oz-in
- Speeds to 50 rps (3,000 rpm) continuous
- 16 user selectable motor resolutions to 50,800 steps/rev
- Three-state current control for reduced motor heating
- User-selectable current waveform for smooth operation
- Zero phase input resets phase currents to the power up positions
- Fault output for remote signalling and diagnostics
- Optically isolated step and direction, shutdown and zero phase inputs
- Anti-resonance eliminates mid-range instability

Protection

- Safety interlock in the motor connector to prevent connector damage if connector is removed with power applied
- Fully short circuit protected—phase-to-phase and phase-to-ground with no time limit
- Enclosed to prevent contaminants from entering the drive enclosure
- Power dump circuitry protects the drive from large inertial loads

Interface Capability

- RP240 remote panel interface, see page C119

Physical

- Nine motors with 10 foot motor cables. Available in 23, 34 and 42 frame sizes
- Drive status indicators; power, step input, undervoltage, overvoltage and motor fault

The S Series

The Compumotor optically isolated step and direction interface is provided, allowing

the S Drive to connect to any Compumotor indexer or the user's pulse train.

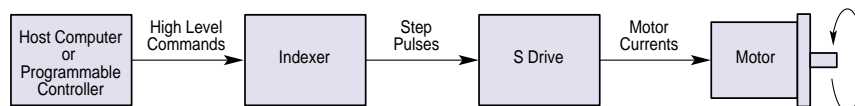

UL and CE (LVD)

SX Series

- Extended edition of X programming language
- Motion calculation delay times as low as 500 microseconds
- Conditional branching commands
- Separate acceleration and deceleration commands
- 50 user defined variables
- Registration input
- Complete specifications begin on page C69

SXF Series

- All of the features of the SX Series
- Encoder following controls speed and position of a slave axis based on speed and position of master axis encoder
- Synchronizes speed and position based on registration marks
- Change ratios "on the fly," complex motion profiling
- Complete specifications begin on page C69

The X Series . . . An Indexer and Drive

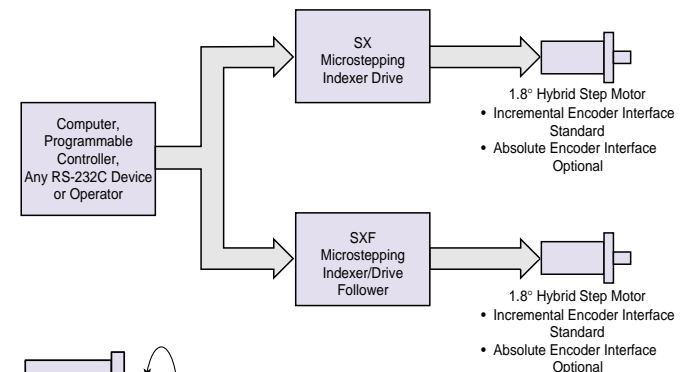

C Step Motor Systems

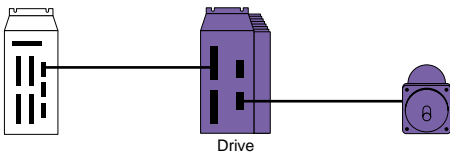

Common Specifications – Model S

Parameter	Value
Performance	
Accuracy	±5 arc min (0.0833°) typical. Unloaded-bidirectional with Compumotor supplied motors. Other motors may exhibit different absolute accuracy. ±1 arc min (0.0167°) Loaded-in addition to unloaded accuracy, per each frictional load equal to 1% rated torque.
Repeatability	±5 arc sec (0.0014°) typical. Unloaded-one revolution returning to start point from same direction.
Hysteresis	Less than 2 arc min (0.0334°) unloaded-bidirectional.
Resolution	16 selectable choices: 200, 400, 1000, 2000, 5000, 10000, 12800, 18000, 20000, 21600, 25000, 25400, 25600, 36000, 50000, 50800
Waveform	Selectable. Allows microstepping shaping for optimum smoothness or relative accuracy. Pure sine; -2%, -4%, -6%, -10%, third harmonic included.
Speed/Torque	Refer to speed-torque curves on page C71.
Motors	
Type	2-phase hybrid permanent magnet, 1.8 degree.
Breakdown voltage (HIPOT)	750VAC minimum
Number of leads	4, 6 or 8
Accuracy Grade	3%
Inductance	0.5 mH minimum; 5.0 to 50.0 mH recommended range; 80.0 mH max
Dimensions	Refer to drawings on page C72.
Amplifier	
Type	20 kHz fixed frequency, variable duty cycle PWM (pulse width modulated). Current controlled, bipolar type. MOSFET, IGBT construction.
Number of phases	2
Dimensions	Refer to dimensional drawings on pages C73 and C74.
Protection*	
Short Circuit	Phase-to-phase, phase-to-ground.
Brownout	If AC supply drops below 85VAC.
Overtemperature	If internal air temperature exceeds 158°F (70°C).
Auto standby	If selected, motor current ramps to 75%, 50% or 25% of preset value if no step pulses are received for 1 second. Rated current levels are resumed upon receipt of next step pulse.
Self test	This feature (used primarily for testing and verification of correct wiring) rotates the motor at approximately 1 rps for 6 revolutions in the CCW direction and 6 revolutions in the CW direction.
Step Input	High-going pulse, 200 nsec min. width; max. pulse rate is 2 MHz. User-supplied driver for the step and direction inputs should be capable of providing a minimum of 6.5 mA to a maximum of 15 mA.
Direction Input	Logic High = positive (CW) rotation. Logic Low = negative (CCW) rotation. User-supplied driver for the step and direction inputs should be capable of providing a minimum of 6.5 mA up to 15 mA.
Shutdown Input	Logic High = amplifier disable. Logic Low = normal operation. User-supplied driver for the shutdown and zero phase inputs should be capable of providing a minimum of 2.5 mA up to 30 mA.
Zero phase	Logic Low = resets the motor phase currents to the zero state. It is primarily for linear motor applications. The input must be active for 100 ms before the first step pulse is received. Logic High = normal operation. User-supplied driver for the shutdown and zero phase inputs should be capable of providing a minimum of 2.5 mA up to 30 mA.
Fault Output	Conducting = normal operation. Not conduction = drive fault.
Power Input	90-130VAC 50/60 Hz
Environmental	
Operating	32°F to 122°F (0°C to 50°C)
Drive	Maximum allowable ambient temperature is 122°F (50°C). Fan cooling may be required if airflow restricted.
Motor	212°F (100°C) maximum motor case temperature. Actual temperature rise duty cycle dependent.
Storage	-40°F to 185°F (-40°C to 85°C)
Humidity	0-95%, non-condensing
Physical	
Drive Dimensions	Refer to drawings on p. C73 and C74.
Drive Weight	S6: 7.50 lbs (3.41 kg); S8: 9.64 lbs (4.38 kg)

* Drive shuts down in conditions listed. Power must be cycled to resume operations.

Common Specifications – Models SX and SXF

Parameter	Value
Power	
Voltage	90-130VAC
Frequency	50-60 Hz less than 8.3 Amps RMS max (motor dependent)
Performance	
Stepping Accuracy	±0 steps from preset total
Velocity Accuracy	±0.02% of max rate above 1 rps
Velocity Repeatability	±0.02% of max rate
Motor Resolutions	200, 400, 1000, 2000, 5000, 10000, 12800, 18000, 20000, 21600, 25000, 25400, 25600, 36000, 50000, 50800 steps/rev
Position Range	±0–99,999,999 steps
Velocity Range	0.00001 to 50.0 rps 0.00001 to 35.0 rps (50,800 steps/rev) 0.00001 to 36.0 rps (50,000 steps/rev)
Acceleration Range	0.01 to 9999.99 rps ²
Speed/Torque	Curves located on page C71
RS-232C Interface	
Connection	3-wire implementation (Tx, Rx, Gnd).
Parameters	Selectable baud rate (300; 600; 1,200; 2,400; 4,800; 9,600) 8 data bits, 1 stop bit, no parity.
Configuration	Up to 16 indexers may be controlled from a single host RS-232C port in a daisy chain configuration.
Protection*	
Short Circuit	Phase-to-phase, phase-to-ground.
Brownout	If AC supply drops below 85VAC.
Overtemperature	If internal air temperature exceeds 158°F (70°C).
Inputs	
Encoder A, B and Z Channel	Differential or single-ended, active high, <0.5VDC low, >3.0VDC high 4.5mA sink
Max frequency	160KHz (pre-quadrature)
Minimum Pulse Width (Z)	500 nsecs.
Programmable Inputs	Eight inputs may be used for BCD recall of motion programs and for interactive machine control. Optically isolated, voltage range = 5-24V.
Limits, Home, Enable	TTL levels, optically isolated.
Outputs	
Fault Output	5 to 30 volts, maximum
Programmable outputs	Four open-collector, sink current of 35 mA
Motion Programming	
Memory Storage	8 Kbytes battery backed RAM
Number of programs	100 sequences, dynamically allocated to 8K
RS-232C Execution	Program execution may be initiated from the RS-232C interface with RUN command (XR)
BCD Input Execution	Sequence select BCD inputs using thumbwheels or PLC
Power-up Auto Run	Sequences may be automatically executed (#100) on power up
Motors	
Type	2-phase hybrid permanent magnet, 1.8 degree
Accuracy Grade	3%
Inductance	0.5 mH minimum; 5.0 to 50.0 mH recommended range; 80.0 mH max
Environmental	
Operating Drive	32°F to 122°F (0°C to 50°C) Maximum allowable ambient temperature is 122°F (50°C). Fan cooling may be required if airflow restricted.
Storage	-40°F to 185°F (-40°C to 85°C)
Humidity	0–95%, non-condensing
Physical	
Indexer/Drive Dims	SX6 & SXF6: 3.2 x 10.7 x 7.0 (82 x 272 x 179); SX8 & SXF8: 4.6 x 10.7 x 7.0 (117 x 272 x 179)
Indexer/Drive Weight	SX6 & SXF6: 9.60 lbs (4.36 kg); SX8 & SXF8: 11.60 lbs (5.27 kg)

* Drive shuts down in conditions listed. Power must be cycled to resume operations.

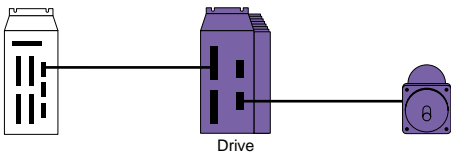

S, SX and SXF Motor Data

		Size 23			Size 34			Size 42		
		S57-51	S57-83	S57-102	S83-62	S83-93	S83-135	S106-178	S106-250	S106-205
		SX57-51	SX57-83	SX57-102	SX83-62	SX83-93	SX83-135	SX106-178	SX106-250	SX106-205
		SXF57-51	SXF57-83	SXF57-102	SXF83-62	SXF83-93	SXF83-135	SXF106-178	SXF106-250	SXF106-205
Static torque										
oz-in		65	100	125	160	300	400	1,000	1,450	1,900
(Nm)		(0.46)	(0.71)	(0.89)	(1.14)	(2.14)	(2.80)	(7.1)	(10.3)	(13.4)
Rotor inertia										
oz-in ²		0.546	1.10	1.69	3.47	6.76	10.47	44.0	63.0	52.0
(kg-cm ²)		(0.100)	(0.201)	(0.309)	(0.635)	(1.24)	(1.92)	(8.05)	(12.14)	(9.51)
Bearings										
Thrust load	lb	25	25	25	50	50	50	50	50	50
	(kg)	(11.3)	(11.3)	(11.3)	(22.6)	(22.6)	(22.6)	(22.6)	(22.6)	(22.6)
Radial load	lb	15	15	15	25	25	25	25	25	25
	(kg)	(6.8)	(6.8)	(6.8)	(11.3)	(11.3)	(11.3)	(11.3)	(11.3)	(11.3)
End play	in	0.005	0.005	0.005	0.005	0.005	0.005	0.005	0.005	0.005
Reversing load	cm	(0.013)	(0.013)	(0.013)	(0.013)	(0.013)	(0.013)	(0.013)	(0.013)	(0.013)
<i>Equal to 1 lb</i>										
Radial play	in	0.0008	0.0008	0.0008	0.0008	0.0008	0.0008	0.0008	0.0008	0.0008
Per 0.5 lb load	cm	(0.002)	(0.002)	(0.002)	(0.002)	(0.002)	(0.002)	(0.002)	(0.002)	(0.002)
Weight (net)										
Motor+Cable										
+Connector	lb	1.6	2.4	3.2	3.8	5.1	8.3	19.1	26.5	23.4
	(kg)	(0.7)	(1.1)	(1.5)	(1.7)	(2.3)	(3.8)	(8.7)	(12.0)	(10.7)
Total shipping weight (net)										
Motor/drive+										
Cables+Container	lb	10.7	11.4	12.3	13.0	14.2	17.4	28.2	35.6	32.5
	(kg)	(4.9)	(5.2)	(5.6)	(5.6)	(6.5)	(7.9)	(12.8)	(16.2)	(14.8)

S, SX and SXF Speed/Torque Curves (Power curve is shown in purple)

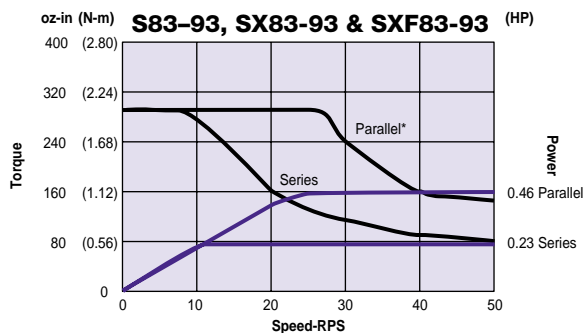
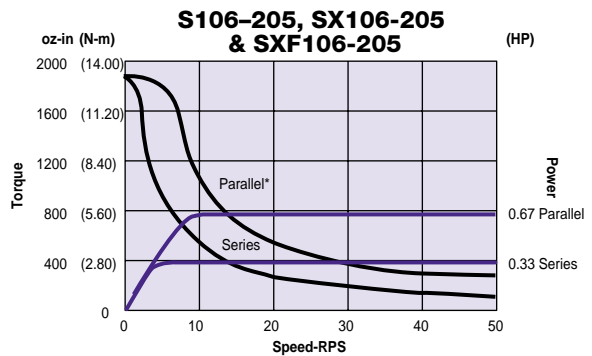
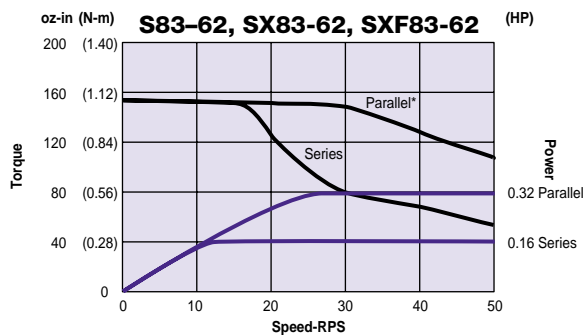
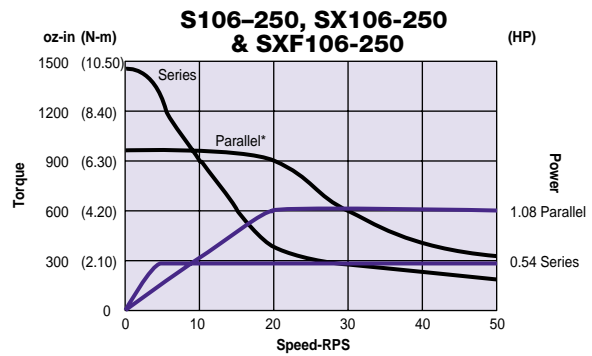
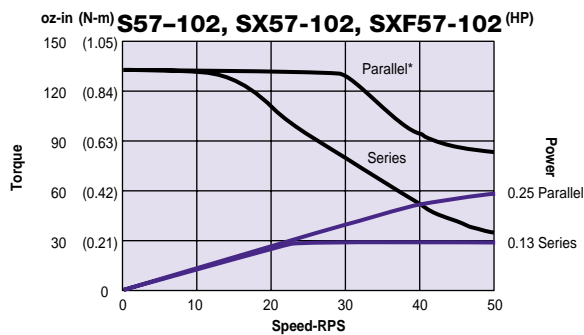
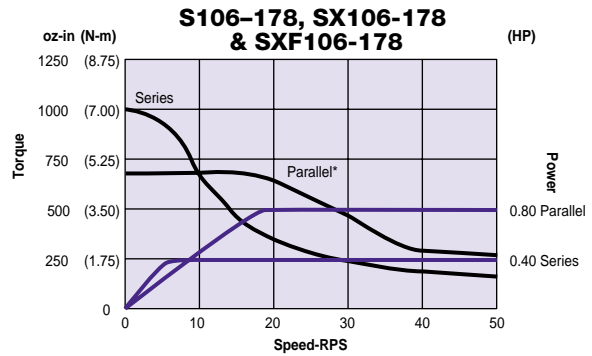
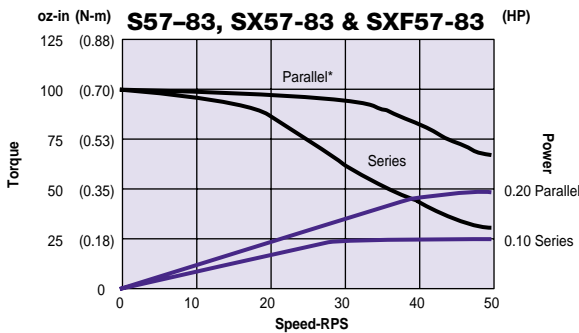
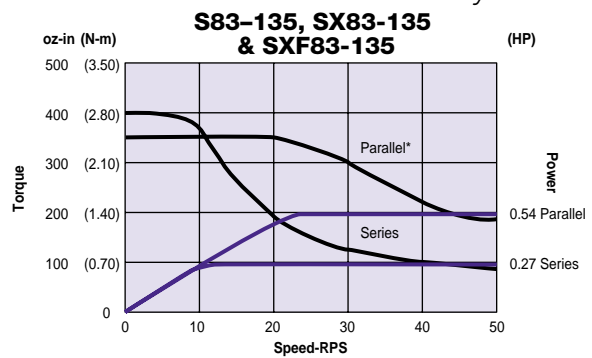
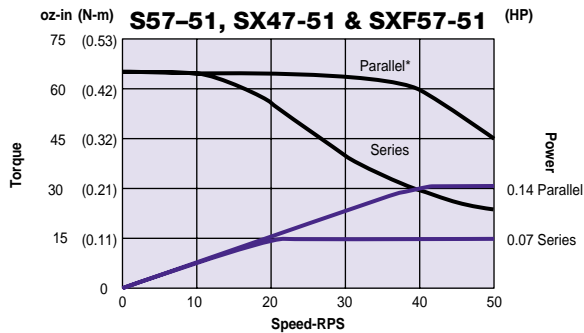

* Parallel connected motors are limited to 50% duty cycle when operated above 5 rps.

For greater than 50% duty cycle above 5 rps, you must connect the motor in series.

Fan cooling the motor will increase duty cycles above 5 rps.

C Step Motor Systems

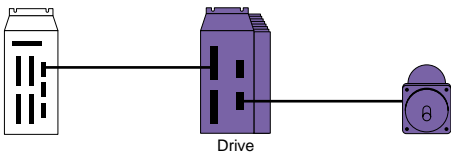

Dimensions (—) denotes millimeters

Size 23 frame

Model	A
S57-51, SX57-51, SXF57-51	2.0 (50.23)
S57-83, SX57-83, SXF57-83	3.1 (75.23)
S57-102, SX57-102, SXF57-102	4.0 (101.6)

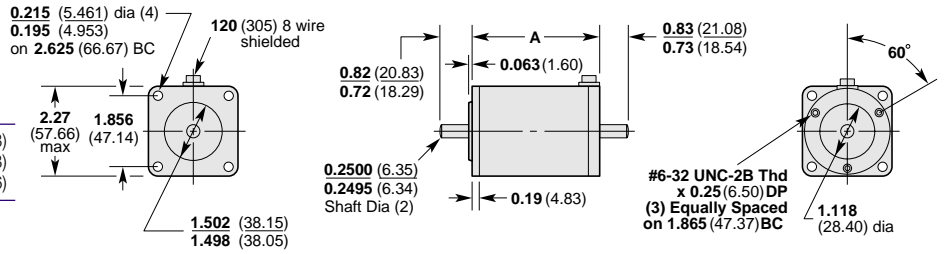

Size 34 frame

Model	A
S83-62, SX83-62, SXF83-62	2.5 (62.0)
S83-93, SX83-93, SXF83-93	3.7 (93.98)
S83-135, SX83-135, SXF83-135	5.2 (129.0)

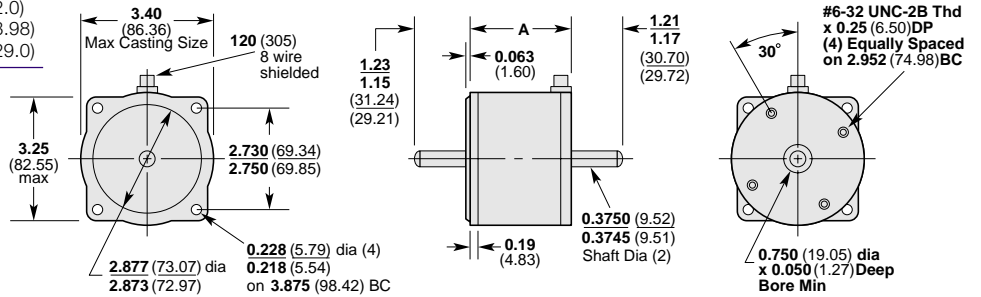

Size 42 frame

Model	A
S106-178, SX106-178, SXF106-178	7.56 (192.02) single endshaft 7.69 (195.32) Double endshaft
S106-250, SX106-250, SXF106-250	9.82 (250.44) single endshaft

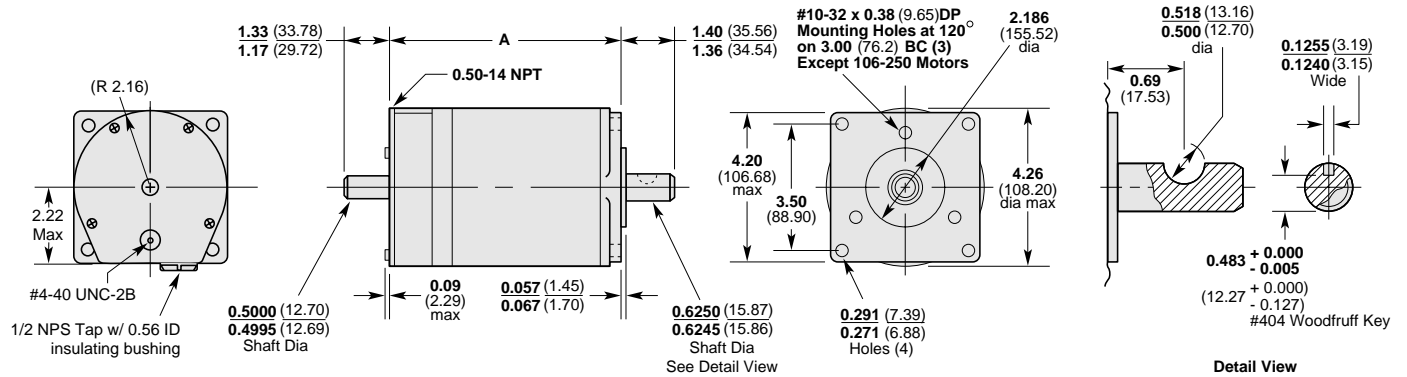

Model S106-205, SX106-205, SXF106-205

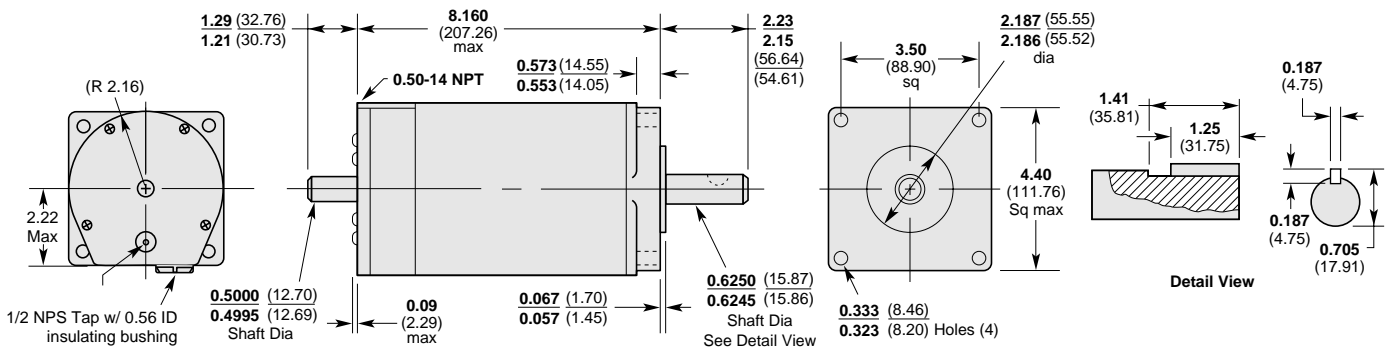

Dimensions (—) denotes millimeters

S Series Drive

S57-51, S57-83, S57-102, S83-62,
S83-93, S83-135

The drive should be mounted with heatsink vertical and connectors on the bottom. Allow a 3" horizontal and 4" vertical clearance between drives.

Low Power (S6) Drive with Heatsink

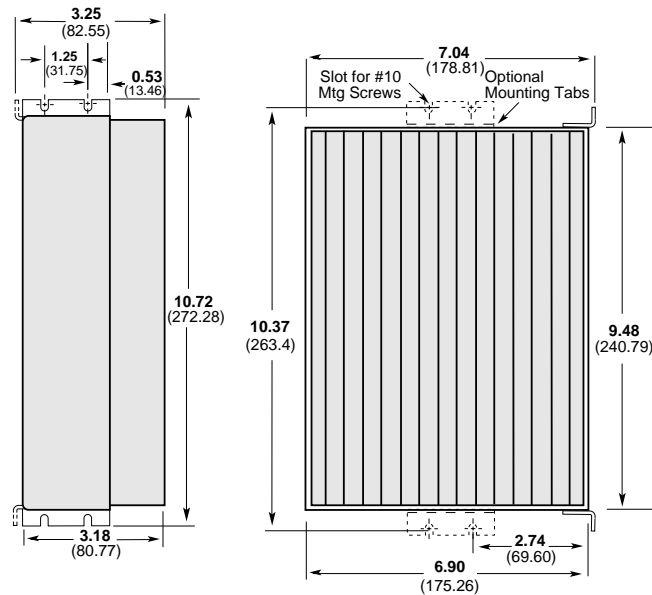

S Series Drive

S106-178, S106-205
(Fan kit; optional with other models)

High Power (S8) Drive with Fan

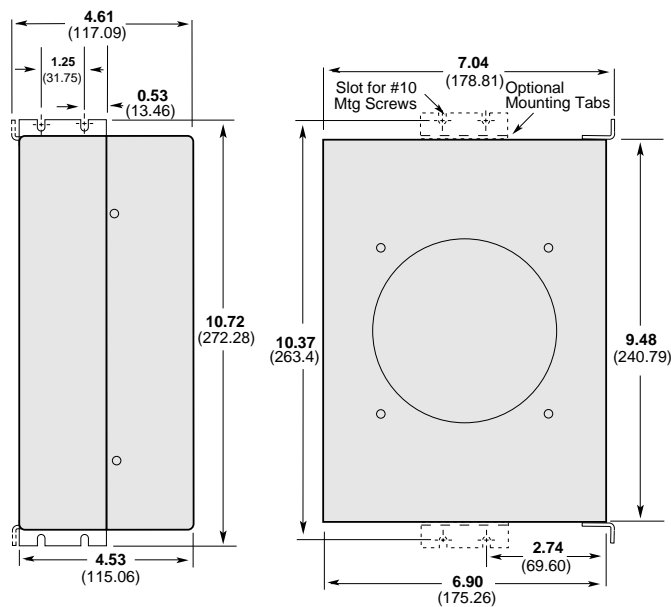

S Drive Connections

Indexer

Standard 25-Pin D Connector

Pin No.	Signal
1	+ Step
2	+ Direction
9	Fault output–collector
11	+ Zero phase
14	– Step
15	– Direction
16	+ Shutdown
17	– Shutdown
21	Fault output–emitter
23	– Zero phase

Motor – Screw Terminal

Pin No.	Signal
1	Interlock
2	A-CT
3	A+
4	A–
5	Gnd
6	B+
7	B–
8	A-CT
9	Interlock

C Step Motor Systems

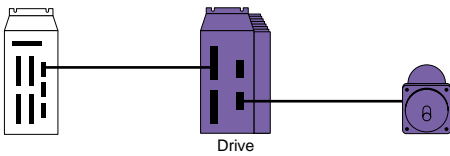

Dimensions (—) denotes millimeters

SX and SXF Series Drives

SX & SXF57-51, SX & SXF57-83, SX & SXF57-102SX & SXF83-62, SX & SXF83-93, SX & SXF83-135

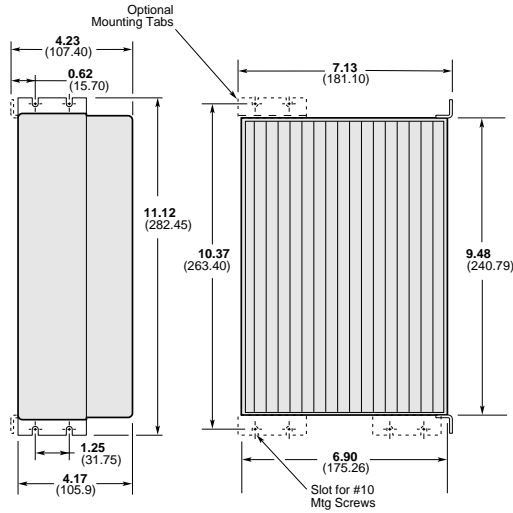

Low Power (S6) Drive with Heatsink

SX and SXF Series Drives

SX & SXF106-178, SX & SXF106-205 (Includes fan kit; optional for other models)

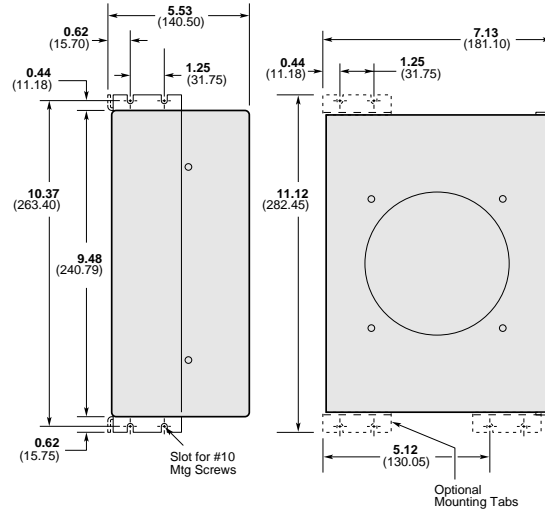

High Power (S8) Drive with Fan

The drive should be mounted with heatsink vertical and connectors on the bottom. Allow a 3" horizontal and 4" vertical clearance between drives.

SX and SXF Drive Connections

Motor Screw Terminal Pin No.	Signal	Encoder Screw Terminal Pin No.	Signal
1	Interlock	1	+5V
2	A-CT	2	GND
3	A+	3	CHA+
4	A-	4	CHA-
5	GND	5	CHB+
6	B+	6	CHB-
7	B-	7	CHZ+
8	B-CT	8	CHZ-
9	Interlock	9	ACC
		10	GND
		11	Shield
		12	OP1-HV
		13	OP2-HV

Note: These pins are also used to connect a Compumotor Model AR-C or AL-C absolute encoder.

Inputs/Outputs

24-pin Screw Terminal Pin No.	Signal
1	RX-RS-232C
2	TX-RS-232C
3	GND-RS-232C
4	+5V
5	Opto 1
6	CW limit
7	CCW limit
8	Home
9	Opto 2
10	Registration
11	Input 1
12	Input 2
13	Input 3
14	Input 4
15	Input 5
16	Input 6
17	Input 7
18	Input 8
19	Output 1
20	Output 2
21	Output 3
22	Output 4
23	Fault
24	GND